



License Plate / Turn Signal Relocation Kit - Model HTSMS-01/HTSMS-02/ HTSMS-03/HTSMS-04

Application

Harley Davidson 2018 Street Bob/ Slim/ Fat Bob/Fat Boy/Breakout

Before you begin, read and understand these instructions and check to be sure all parts are accounted for.

<u>Qty.</u>	<u>Part Description</u>
1	Mounting Bracket
1	Lighted License Plate Frame
1	Directional Standoff
2	Electrical Extenders
2	Electrical Connectors
5	Adhesive Backed Wire Clips
3	Push-In Wire Ties

Installation Instructions

Note: A licensed Harley Davidson technician should be consulted before beginning installation of the HTSMS 01-04 Kit. The following instructions are intended to provide general instructions for the installation of the relocation kit.

1. Place the motorcycle on a safe and secure motorcycle jack. (see fig.1)
2. Remove the seat to access the turn signal and license plate light plugs. The left turn signal plug is grey, the right turn signal plug is black (see fig.2) The electrical plugs need to be removed and reinstalled after installation of the Mounting Bracket to avoid cutting the turn signal wires. (see fig.3) The wires must be reinstalled in the plug exactly as removed. The license plate light wires will need to be cut approximately 6" from connector plug to connect to the lighted license plate frame wires. Remove the (3) push in wire ties at the front of the fender.
3. Remove the (4) forward fender strut bolts at the frame connection point at the seat to remove the fender and strut assembly from the motorcycle. (see fig.4) (Have a protected stable work table prepared ahead of time to prevent scratching the fender). Remove the red reflector at the rear of the fender.)
4. Remove the 3 bolts (two outside, one inside) on each fender strut that hold the fender struts to the fender, to gain access to the rear turn signal mounting bolts and wiring. Remove the wiring and turn signals from the fender struts. The left side Directional Standoff will be replaced by the new included Directional Standoff when the turn signals are reinstalled.
5. Install the license plate and lighted frame onto the Mounting Bracket using the supplied screws with nylon lock nuts. (Note: a small notch at the top center of the license plate may be required to allow for lighted license plate frame wires. (see fig.5)
6. Install the fender struts and turn signal/ license plate mounting bracket onto the fender reusing the stock rear 3/8 button head bolts. The mounting bracket will mount between the inner fender support bracket and the fender. The hole in the Mounting Bracket will slip over the boss in the inner fender support bracket. Ensure that the inner fender support bracket is securely in the "C" channel at the end of the Turn Signal/License plate relocation bracket mounting arm.. (see fig.6) Install the adhesive wire clips. (see Item 8. and fig. 8)
7. Install the rear turn signals onto the Mounting Plate reusing the 5/16 hex head bolts with flat and lock washers. Reinstall the electrical plugs. Attach the lighted license plate frame wires to the license plate light wires from the motorcycle (butt connectors were supplied for this). Note: Black to black and white (lighted license plate frame) to blue(motorcycle)
8. For the best adhesion clean the inside of the fender before you Install the three (3) adhesive backed wire clips along the inside of the fender on the left. Install two (2) adhesive backed wire clips along the inside of the fender on the right above each mounting bolt. (see fig.8)Clip the license plate wires together with the turn signal wires into the clips.
9. Reinstall the fender and strut assembly to the motorcycle
10. Route the wires back under the front of the fender and secure with the provided push-in wire ties. Ensure all electrical wires have a safe clearance from tire.
11. Add the provided wire extensions and reconnect the turn signals. Test all electrical functions. Reinstall the seat.

Notice to Consumer

Neither the manufacturer, nor the distributor nor the retailer of the Mounting System makes any express warranties of any kind with respect to the Mounting System. Any implied warranty does not cover defects caused by modification or alterations of the Mounting System or caused by physical abuse to or misuse of the Mounting System or its use and/or operation in a manner contrary to the accompanying instructions. Failure to install and/or use the Mounting System in the manner described by the accompanying instructions shall render all warranties, expressed and/or implied, void and release the manufacturer, distributor and retailer from any and all liability arising from the use of the Mounting System.,.

**For product support, damaged or missing parts, please contact Great Bike Gear, Inc. at 866-521-3024
Do not return product without prior authorization.**



fig.1



fig.2

Turn Signal Connector Removal

1. After removal of the tail light lens, disconnect the turn signal connector from the electrical terminal by depressing the Release button. (1)
2. Open the Secondary lock. (3) Note the wire color locations for correct reconnection.
3. Using a Pin or small screw driver (6) release the Tang (4) from the Socket terminal (5) while gently pulling the wire from the connector.
4. For addition information search YouTube for “Harley Davidson OEM wire signal connector molex harness Plug removal-How to take apart”
5. Reverse the procedure for reconnection.

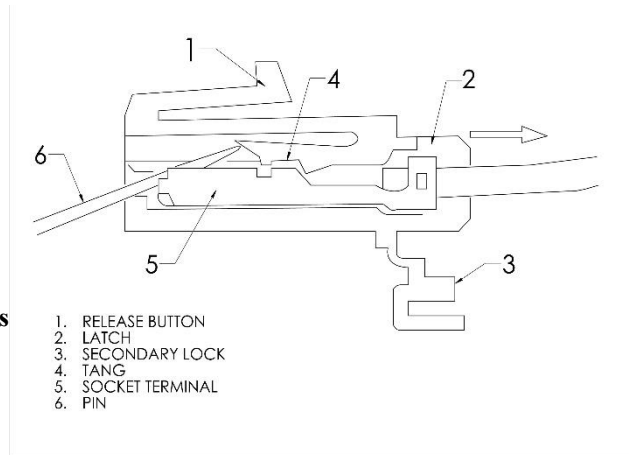

fig.3

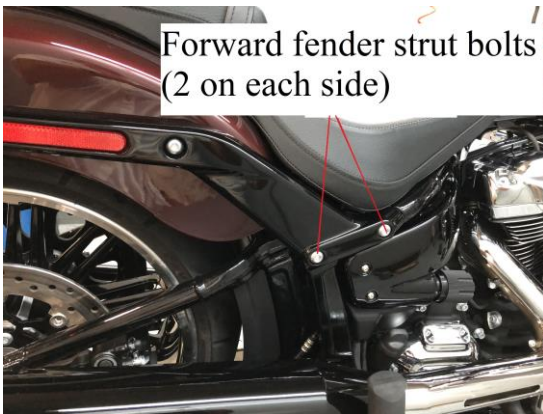

fig.4



fig.5

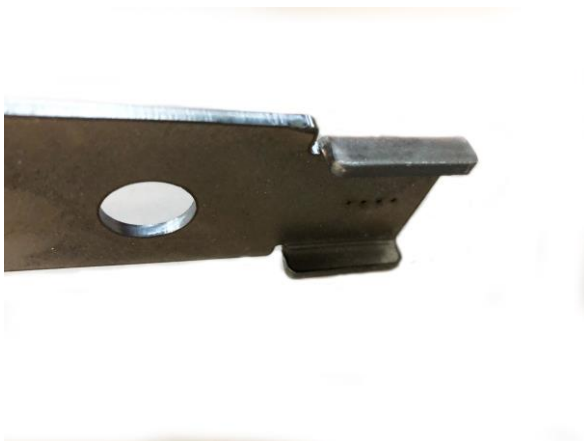

fig.6



fig.7

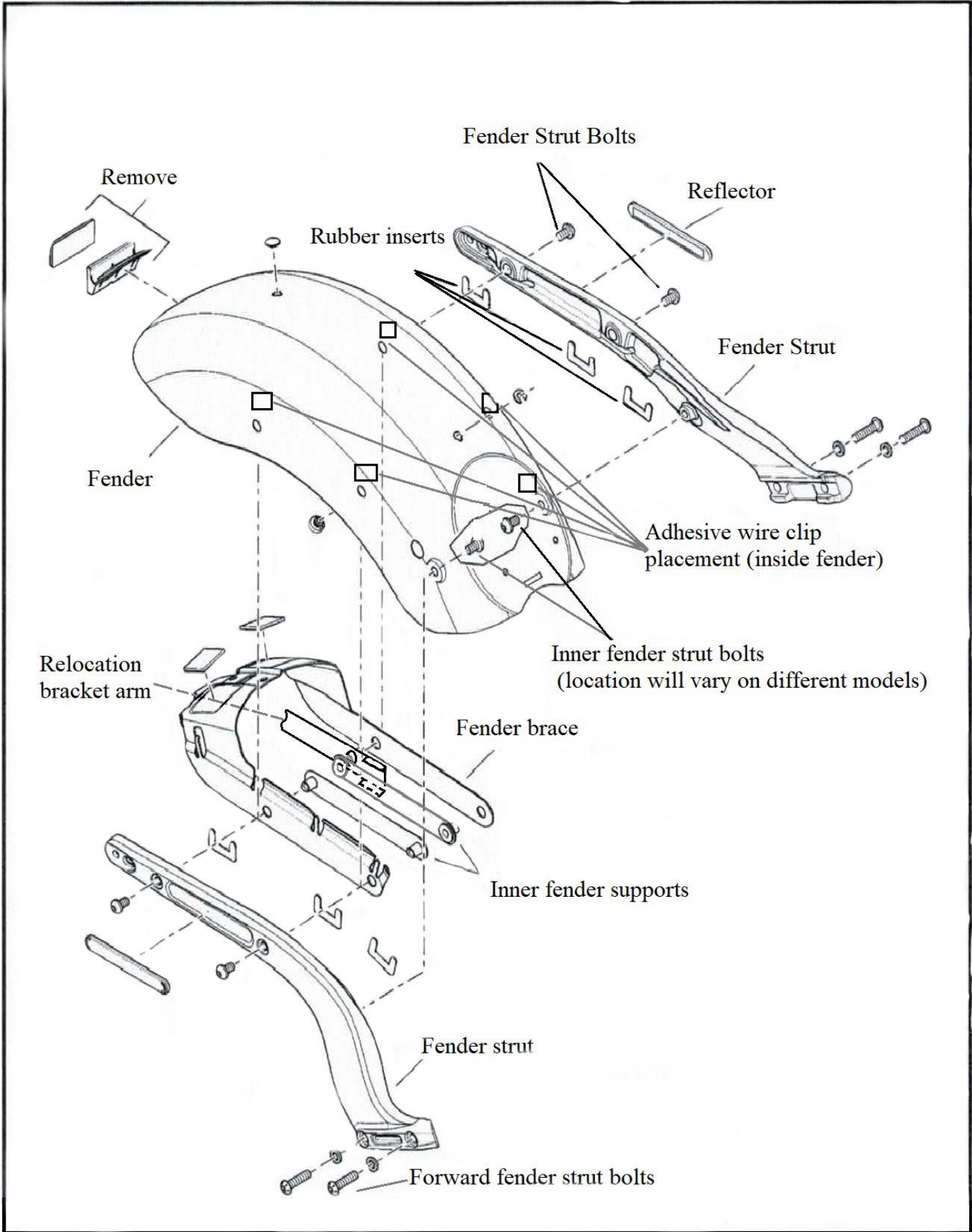

fig.8